

# UPM3

Installation and operating instructions





# UPM3

---

## English (GB)

Installation and operating instructions .....	4
<b>Declaration of conformity .....</b>	<b>22</b>
<b>Declaration of conformity .....</b>	<b>23</b>

## English (GB) Installation and operating instructions

### Original installation and operating instructions

#### Table of contents

<b>1. General information</b>	<b>4</b>
1.1 Hazard statements	4
1.2 Notes	4
<b>2. Product introduction</b>	<b>5</b>
2.1 Product description	5
2.2 Pumped liquids	5
2.3 Identification	5
<b>3. Receiving the product</b>	<b>6</b>
3.1 Transporting the product	6
3.2 Inspecting the product	6
<b>4. Mechanical installation</b>	<b>7</b>
4.1 Control box positions	8
4.2 Checking the direction of rotation	8
4.3 Preventing the pump from blocking	8
4.4 Insulation	8
<b>5. Electrical connection</b>	<b>9</b>
5.1 Wiring diagram	9
5.2 Supply voltage	9
5.3 Earth leakage circuit breaker (ELCB)	9
5.4 Control box connections	9
<b>6. Startup</b>	<b>12</b>
6.1 Before startup	12
6.2 Starting up the product	12
<b>7. Operating panel and settings</b>	<b>13</b>
7.1 UPM3	13
7.2 UPM3 HYBRID variants	13
7.3 Control modes	13
7.4 Overview of operating panel control modes	13
7.5 Control mode explanation	14
7.6 Selection of control mode	16
<b>8. External control mode and signals</b>	<b>16</b>
8.1 Control principles	16
8.2 Control signals	16
<b>9. Service</b>	<b>19</b>
9.1 Maintaining the product	19
9.2 Cleaning the product	19
<b>10. Storing the product</b>	<b>19</b>
<b>11. Fault finding</b>	<b>20</b>
11.1 Noise in the pump	20
11.2 Noise in the system	20
11.3 Pump is not running, no power supply	20
11.4 Pump is not running, normal power supply	20
11.5 Insufficient flow	20
11.6 Pump runs at maximum speed and cannot be controlled	20
11.7 Fault indication on the operating panel	20
<b>12. Technical data</b>	<b>21</b>
12.1 Operating conditions	21
<b>13. Disposing of the product</b>	<b>21</b>

## 1. General information

This appliance can be used by children aged from 8 years and above and persons with reduced physical, sensory or mental capabilities or lack of experience and knowledge if they have been given supervision or instruction concerning use of the appliance in a safe way and understand the hazards involved.

Children shall not play with the appliance. Cleaning and user maintenance shall not be made by children without supervision.



Read this document before you install the product. Installation and operation must comply with local regulations and accepted codes of good practice.

### 1.1 Hazard statements

The symbols and hazard statements below may appear in Grundfos installation and operating instructions, safety instructions and service instructions.



#### DANGER

Indicates a hazardous situation which, if not avoided, will result in death or serious personal injury.



#### WARNING

Indicates a hazardous situation which, if not avoided, could result in death or serious personal injury.



#### CAUTION

Indicates a hazardous situation which, if not avoided, could result in minor or moderate personal injury.

The hazard statements are structured in the following way:

#### SIGNAL WORD

##### Description of the hazard

Consequence of ignoring the warning

- Action to avoid the hazard.

### 1.2 Notes

The symbols and notes below may appear in Grundfos installation and operating instructions, safety instructions and service instructions.



Observe these instructions for explosion-proof products.



A blue or grey circle with a white graphical symbol indicates that an action must be taken.



A red or grey circle with a diagonal bar, possibly with a black graphical symbol, indicates that an action must not be taken or must be stopped.



If these instructions are not observed, it may result in malfunction or damage to the equipment.



Tips and advice that make the work easier.



## 2. Product introduction

### 2.1 Product description

UPM3 are speed-controlled, high-efficiency pumps fitted with an electronically commutated motor (ECM) with permanent-magnet rotor and frequency converter. They are either externally controlled by digital pulse-width modulation (PWM) low-voltage signal, LIN bus signal or internally controlled in constant pressure, proportional pressure or constant speed mode defined by a smart operating panel or factory presetting.

### 2.2 Pumped liquids

#### WARNING Biological hazard



Death or serious personal injury

- In domestic hot-water systems, the temperature of the pumped liquid must always be according to local legislation.

#### CAUTION Flammable material



Minor or moderate personal injury

- Do not use the pump for flammable liquids, such as diesel oil and petrol.

#### CAUTION Corrosive substance



Minor or moderate personal injury

- Do not use the pump for aggressive liquids, such as acids and seawater.



Frost protection fluids may contain substances that can harm the terminal box material. Grundfos recommends shielding the terminal box from exposure to the frost protection fluids.

The product is suitable for pumping clean, thin, non-aggressive and non-explosive liquids, not containing solid particles or fibres.

In heating systems, the water must meet the requirements of accepted standards on water quality in heating systems, for example the German standard VDI 2035.

The pH must be between 8.2 and 9.5. The minimum value depends on the water hardness and must not be below 7.4 at 4 °dH (0.712 mmol/l).

The electrical conductivity at 25 °C must be equal to or larger than 10 microS/cm.

Mixtures of water with antifreeze media, such as glycol, with a kinematic viscosity lower than 10 mm<sup>2</sup>/s (10 cSt). When selecting a pump, the viscosity of the pumped liquid must be taken into consideration. If the pump is used for a liquid with a higher viscosity, the hydraulic performance of the pump is reduced.

Solar media used in typical solar thermal systems containing up to 50 volume % of antifreeze media.

For drinking water use, approved housings must be used, such as CIL3 PPS or stainless steel N. These pumps are WRAS (UK) and ACS (FR) approved, and the materials in contact with drinking water comply with the applicable evaluation criteria issued by UBA (DE).

In domestic hot-water systems, the pump must be used only for water with a degree of temporary hardness of less than 3 mmol/l CaCO<sub>3</sub> (16.8 °dH). To avoid lime problems in hard water, the liquid temperature must not exceed 65 °C.

The water quality of test beds for the final production tests of complete heating appliances including pump must be observed to avoid calcification or biofilm formation during a longer storage period.

### 2.3 Identification

#### 2.3.1 Type key

Example: UPM3 SOLAR 15 - 145 130 C A X 9 XXX

Code	Explanation	Designation
UPM3	Standard	Pump type
UPM3S	Small version with IMM rotor	
UPM3L	Large version with extended P1	
UPMO	For ErP upgrade and replacement	

Code	Explanation	Designation
F	For flammable refrigerant environments	Control variant
K	Cold water	
FLEX AS	PWM A, MAX	
SOLAR	PWM C, CC	
DHW	PWM A, MAX	
AUTO	PP, CP, CC, AA	
HYBRID	PWM A/C, PP, CP, CC, AA	
LIN	LIN bus	

Code	Explanation	Designation
15	R 1/2" / G 1"	Nominal diameter
25	R 1" / G 1 1/2"	
32	R 1 1/4" / G 2"	

Code	Explanation	Designation
20	2 m	Maximum head
40	4 m	
50	5 m	
60	6 m	
70	7 m	
75	7.5 m	
105	10.5 m	
145	14.5 m	

Code	Explanation	Designation
130	Cast iron CED, 130 mm	Pump housing
180	Cast iron CED, 180 mm	
N 130	Stainless steel, 130 mm	
N 150	Stainless steel, 150 mm	
N 180	Stainless steel, 180 mm	
GGES2	Cast iron CED, end suction UPM3	
GGAOS3	Cast iron CED, AOS3 UPM3	
GGMBP3	Cast iron CED, GGMBP3 UPM3	
GGBP3	Cast iron CED, GGBP3 UPM3	
CIL3PA	Composite CIL3, PA6.6 UPM3	
CIL3PP	Composite CIL3, PPS UPM3	
CIAO2A	Composite CIAO2 AC	Pump housing
CIAO2	Composite CIAO2	
CESAO1	Composite CESAO1	
CESAO2	Composite CESAO2	
CESAO4	Composite CESAO4	
CACAO	Composite CACAO	
AOKR	Composite AOKR	
CAOD3	Composite CAOD3 UPM3	

Code	Explanation	Designation
A	PWM A profile, heating	External control signals 1 and 2
C	PWM C profile, solar	
N	LIN bus	
Z	No profile	

Code	Explanation	Designation
A	0-563 rpm	Minimum speed
J	> 2.025 rpm	

Code	Explanation	Designation
X	TE MSS NdFeB Relay	Control signal connector
Y	FCI NdFeB Relay	
V	TE MSS NdFeB NTC	
W	FCI NdFeB NTC	
T	TE MSS IMM NTC	
U	FCI IMM NTC	

Code	Explanation	Designation
3	3 h (right)	Control box orientation
6	6 h (below)	
9	9 h (left)	
0	12 h (top)	

Code	Explanation	Designation
XXX		Customer code

2.3.2 Nameplate options

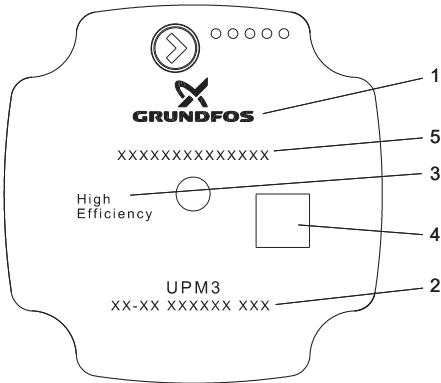

Nameplate: Grundfos standard

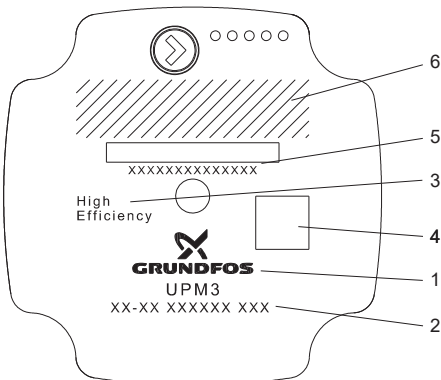

Nameplate: customised layout

Pos.	Description
1	Grundfos logo
2	Grundfos pump type
3	High efficiency indicating ECM technology
4	Grundfos data matrix
5	Customer product number or barcode
6	Area for customer specific logo

2.3.2.1 Terminal box side

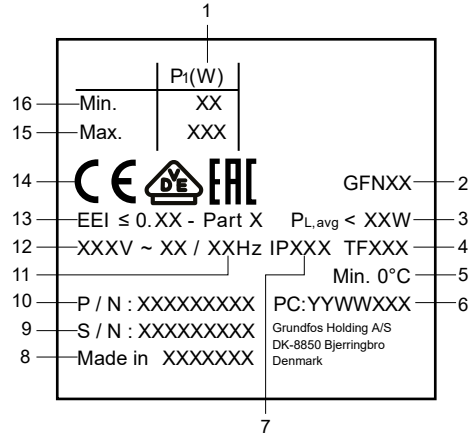

Terminal box side

Pos.	Terminal box side
1	Input power at minimum and maximum performance
2	Product mark (legal product code)
3	Average power input $P_{L,avg}$ (Ecodesign regulation)
4	Temperature class
5	Minimum liquid temperature (only cold-water pumps)
6	Production code (year and week) and customer ID
7	Enclosure class
8	Production site
9	Serial number
10	Product number
11	Frequency [Hz]
12	Voltage [V]
13	Energy index with indication of measurement standard
14	CE mark and approvals
15	Maximum
16	Minimum

3. Receiving the product

3.1 Transporting the product

- Use appropriate lifting and transporting devices.
- Observe the maximum stacking height of pallets printed on the side of the pallet.

3.2 Inspecting the product

When you have received the product, make sure that:

- The product is in accordance with the order.
- The voltage and frequency of the product match the voltage and frequency of the installation site.

TM075431

TM075430

TM076077

### 4. Mechanical installation



Mechanical installation must be carried out by trained persons in accordance with local regulations.



The pump must always be installed with horizontal motor shaft within  $\pm 5^\circ$ .



Arrows on the pump housing indicate the liquid flow direction through the pump. The pump is designed to be installed with horizontal shaft pumping upwards, downwards or horizontally.

- The pump must be installed in the system in such a way that no major amount of air flowing through or gathering in the pump housing affects the pump when it is out of operation.
  - If an additional non-return valve is installed in the flow pipe, there is a high risk of dry running as the air cannot pass the valve.
  - It must be possible to vent the system at the highest part of each system segment.
  - Permanent venting is recommended.
1. Check the arrows on the pump housing for flow direction through the pump. The flow direction can be horizontal or vertical, depending on the control box position.

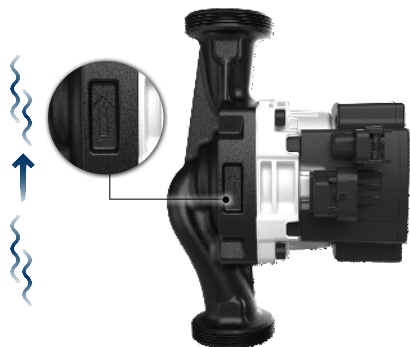

TM078758

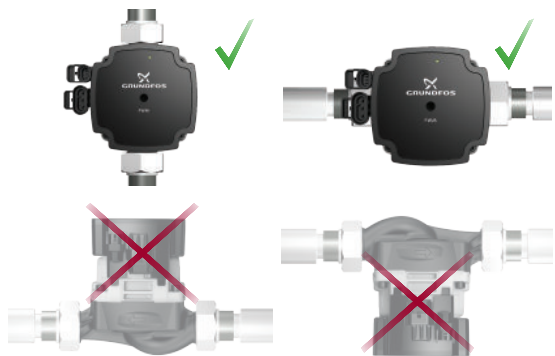

TM080999

2. Close the isolating valves and make sure that the system is not pressurised during the installation of the pump.

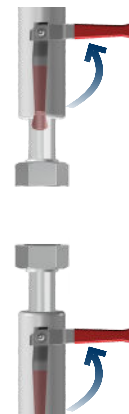

TM078759

3. Mount the pump with gaskets in the pipes.

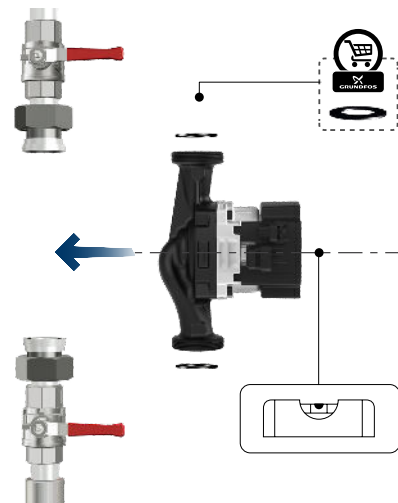

TM078760

4. Tighten the union nuts (maximum 30 Nm).

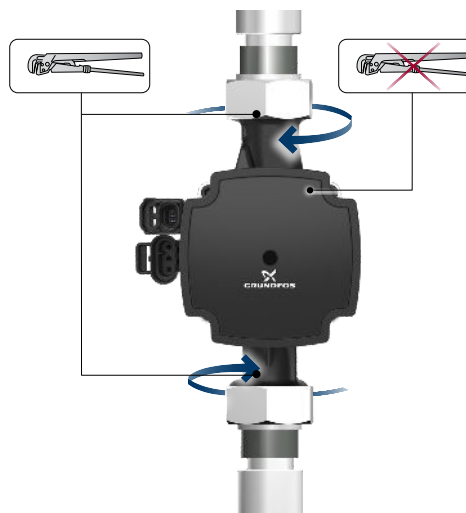

TM078761



In heating systems, do not insulate the control box or cover the operating panel.

#### 4.1 Control box positions

The control box gives access to the terminals from the front. If necessary, you can turn the control box in steps of 90 degrees:

- 3 o'clock
- 6 o'clock
- 9 o'clock
- 12 o'clock

By default, the operating panel is in the top position (12 o'clock) when the terminals are in 9 o'clock position. The front foil can be placed in four different positions. This allows you to place it in a horizontal position no matter the orientation of the control box.

Observe the following:

- IP44 versions without drain holes - all positions are allowed.
- IPX4D versions with drain holes (UPM3K, UPM3 SOLAR) - the drain hole must point downwards after installation. Only connector positions to the side are possible.

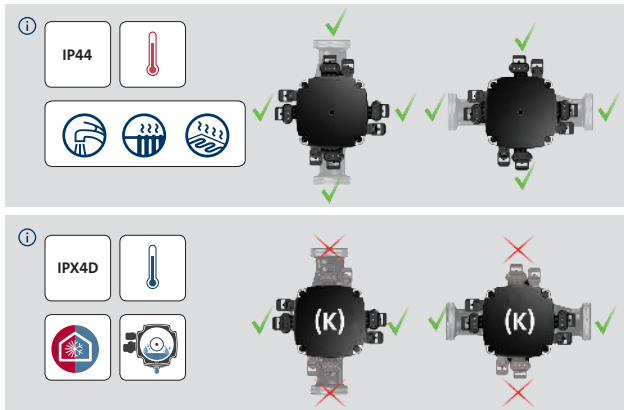

TM064409

##### 4.1.1 Changing the control box position

1. Remove the screws that hold the pump head.
2. Turn the control box into the desired position.
3. Fit the screws.
4. Tighten the new screws securely.

The nameplate position cannot be changed.



Before dismantling the pump, drain the system or close the isolating valves on both sides of the pump.

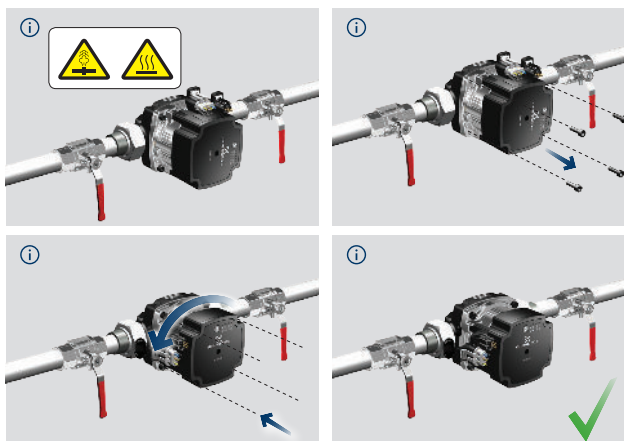

TM064410

Changing the control box position

#### 4.2 Checking the direction of rotation

Three-phase pumps only

Check the direction of rotation every time the pump is connected to a new installation.

1. Position the pump so that you can observe the impeller.
2. Start the pump for a short period.

3. Observe the rotation of the impeller. The correct direction of rotation is indicated by an arrow on the inlet strainer (clockwise when seen from the bottom). If the impeller rotates in the wrong direction, reverse the direction of rotation by interchanging two of the phases to the motor.

If the pump is connected to a pipe system, check the direction of rotation in this way:

1. Start the pump and check the quantity of water or the pressure.
2. Stop the pump and interchange two of the phases to the motor.
3. Start the pump and check the quantity of water or the pressure.
4. Stop the pump.

Compare the results taken under points 1 and 3. The largest quantity of water indicates the correct direction of rotation.

#### 4.3 Preventing the pump from blocking

To prevent the pump from blocking, do the following:

1. Once installation is complete, the pump must run for two hours to vent the system.
2. Make sure that the pump runs for a period of time every day.

#### 4.4 Insulation

When insulating the pump, the front plate of the control box must not be covered in order to allow for cooling by the surrounding air.

If the pump is installed inside a cabinet, a boiler or a heating kit encapsulated with insulating shells, the inside air temperature has to be measured, and it must not exceed 70 °C during operation.

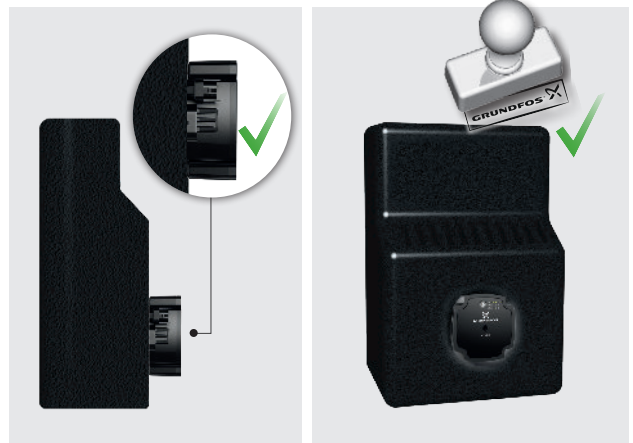

TM064411

Insulation of a pump

## 5. Electrical connection

### WARNING Electric shock



Death or serious personal injury

- In case of an insulation fault, the fault current may be a pulsating DC. Observe national legislation about requirements for and selection of Residual Current Device (RCD) when installing the product.

### WARNING Electric shock



Death or serious personal injury

- The pump shall be connected to a supply disconnecting device incorporated in the fixed wiring according to the local wiring rules.

### WARNING Electric shock



Death or serious personal injury

- Switch off the power supply before you start any work on the product. Make sure that the power supply cannot be switched on accidentally.

### WARNING Electric shock



Death or serious personal injury

- Always make sure that the safety earth (PE Protective Earth) on the pump is connected to the PE in the installation



All electrical connections must be carried out by a qualified electrician in accordance with local regulations.

- The pump requires no external motor protection.
- Check that the supply voltage and frequency correspond to the values stated on the nameplate.
- The pump must not be used with an external speed control that varies the supply voltage.
- If an RCD is used, check which type it is.
- If an external relay is used, check if it can stand the inrush current.

### 5.1 Wiring diagram

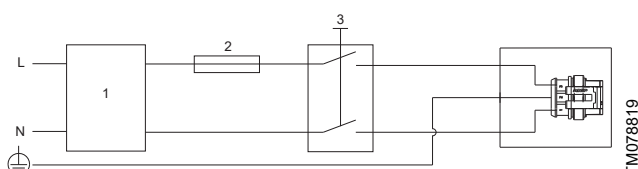

Pos.	Description
1	Residual Current Device (RCD)
2	Fuse
3	External switch

### 5.2 Supply voltage

1 × 230 V +10 % / -15 %, 50/60 Hz.

The pump is externally controlled via PWM signal or LIN bus signal, or internally speed-controlled by a frequency converter. The pump must therefore not be used with an external speed control that varies the supply voltage, for example phase-cut or pulse-cascade control.

#### 5.2.1 Reduced supply voltage

Pump operation is ensured above 160 VAC with reduced performance.

#### Pumps with PWM and LIN bus control

If the voltage falls below 190 VAC, a low-voltage warning is sent via the PWM or LIN bus signal.

If the voltage falls below 150 VAC, the pump stops and a low-voltage alarm is sent via the PWM or LIN bus signal.

#### Pumps in internal control mode

If the voltage falls below 150 VAC, the pump stops and gives an alarm.

Supply voltage	Pump performance	Status LED	PWM output signal
230 VAC	Running	Green	According to specification
<195 VAC	Reduced	Green	Warning
<150 VAC	Stopped	Red	Alarm <sup>1)</sup>

1) The pump starts again when the voltage is above 160 VAC and the PWM output changes to either warning or according to specification depending on the level.

#### Related information

[11.7 Fault indication on the operating panel](#)

### 5.3 Earth leakage circuit breaker (ELCB)

#### DANGER Electric shock



Death or serious personal injury

- In case of an insulation fault, the fault current may be pulsating DC. When installing the pump, observe national legislation about requirements for and selection of Residual Current Device (RCD).

#### 5.3.1 Leakage current

The pump mains filter causes a leakage current to earth during operation.

Leakage current: < 3.5 mA.

### 5.4 Control box connections

All control boxes have two electrical connections on one side:

- power supply connection
- signal connection.

If the signal connection is not needed, it can be covered by a blind plug.

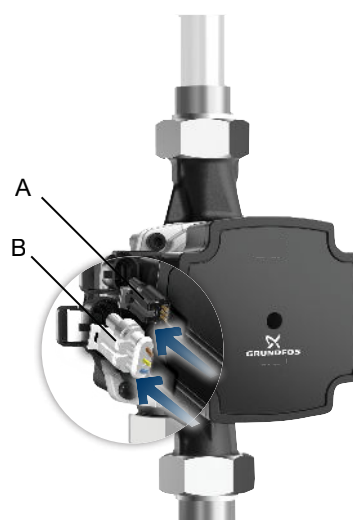

Signal connection and power connection

Pos.	Description
A	Signal connection
B	Power connection

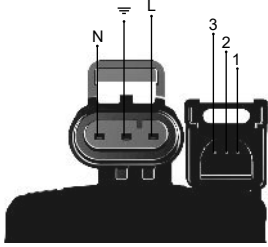

Connections FCI

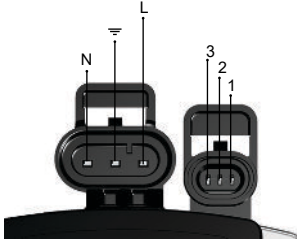

Connections Mini SS

Contact	PWM	LIN	Cable
1	PWM input	VBAT	Brown
2	Signal reference	Signal reference	Blue
3	PWM output	LIN bus signal	Black

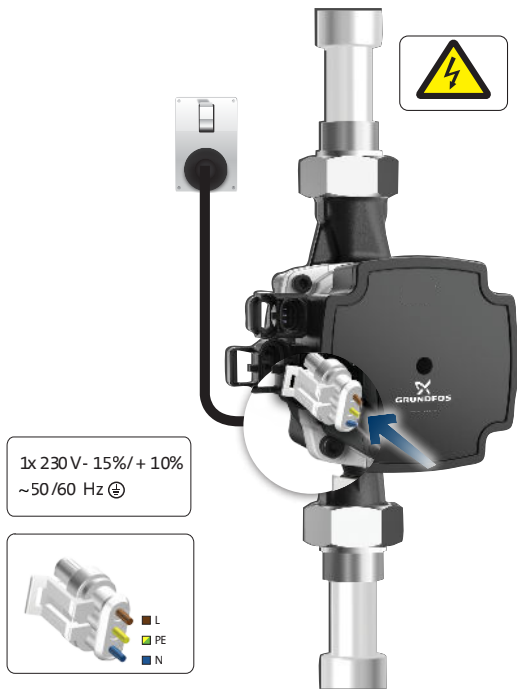

Control box without signal connection

TM068062

TM064416

TM079641

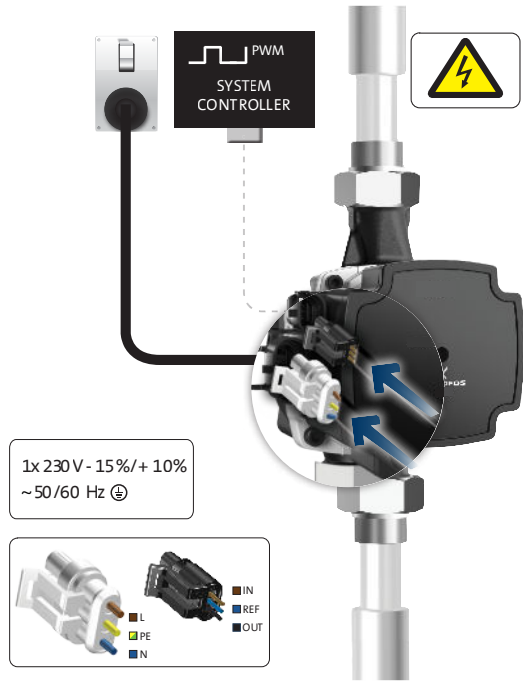

Control box with Mini Superseal connection

### 5.4.1 Power supply connection

The pump must be connected to the power supply with the TE Superseal connector.

Adapters are available for cables with Molex or Volex connectors.

TM079642

### 5.4.2 Control signal connection



Connect the signal wires to the correct poles. Otherwise, the pump may be damaged.

UPM3 pumps are externally speed-controlled. A signal cable is required to enable the pump control. Otherwise, the pump with profile A runs continuously at maximum speed, while the pump with profile C stops.

UPM3 HYBRID pumps are either internally or externally speed-controlled.

If you set the pump to external control mode (PWM A or C profile) via the operating panel, you need a signal cable. If you set the pump to internal control mode, a blind plug can be used to close the signal connection.

The signal cable connection has three leads: signal input, signal output and signal reference. The cable must be connected to the control box by either a FCI or TE Mini Superseal connector.

The cable length can be customised to specific requirements (max. 3 m).

## 6. Startup

### 6.1 Before startup

- The system must be filled with liquid and vented before starting the product.
- Make sure that the required minimum inlet pressure is available at the pump inlet.
- When using the pump for the first time, the system must be vented.

#### Related information

##### [6.2 Starting up the product](#)

### 6.2 Starting up the product

Before you start the pump:

1. Mount the pump in the correct position.
2. Check that the unions are tightened.
3. Check that the valves are opened.
4. Fill the system and vent it above the pump.
5. Check if the required minimum inlet pressure is available at the pump inlet.
6. Switch on the power supply.
7.
  - If the pump is externally controlled: Check if the external controller sends a signal that controls the speed or that might have stopped the pump.
  - If the pump is internally controlled: The pump starts with factory pre-setting (e.g. proportional pressure curve 3). Change the setting if necessary.



Do not start the pump until the system has been filled with liquid and vented.



The pump is self-venting and does not have to be vented before startup. Air inside the pump is transported by the liquid into the system shortly after startup.



- Heating systems must be flushed according to local standards, such as DIN EN 14336 or VOB ATV C DIN 18380, before startup. After filling the system for the first time, the pump must run for approx. 1 hour before a long-term stop.
- Inhibitors and additives increase the risk of malfunction of the pump.
- If filters are installed, they must be monitored and maintained thoroughly.

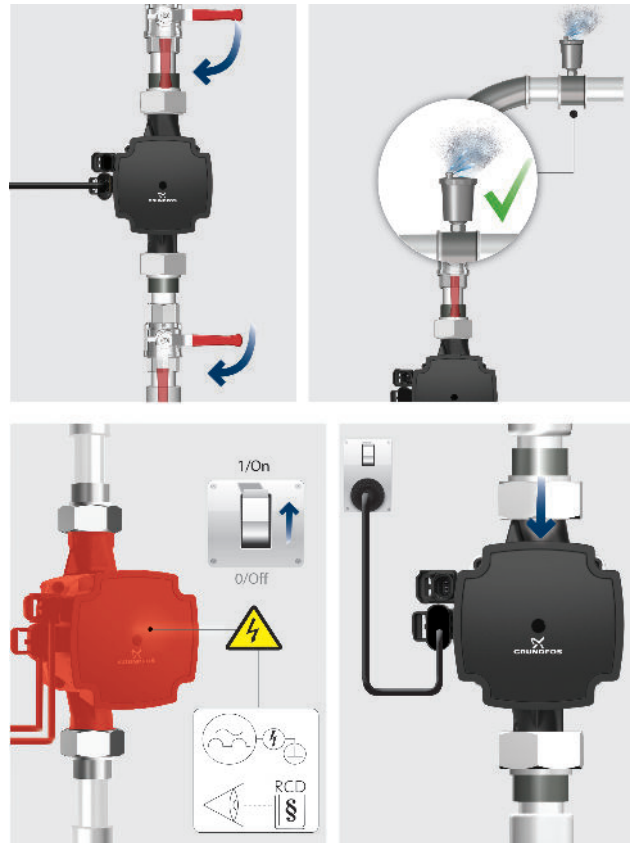

TM079654

#### Related information

##### [6.1 Before startup](#)

##### [7.4 Overview of operating panel control modes](#)

## 7. Operating panel and settings

### 7.1 UPM3

UPM3 is externally controlled via a PWM or LIN bus signal.

#### 7.1.1 Operating panel

The operating panel is designed with one red/green LED.

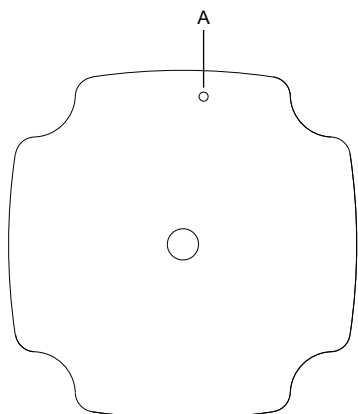

TM075425

UPM3 operating panel

Pos.	Description
A	LED

The LED shows whether the pump is controlled externally or if the pump experiences an error.

	Green LED	Red LED
No external control	•	
External control	• <sup>2)</sup>	
Alarm		•

2) 12 flashes per second.

#### 7.1.2 Alarm status

If the pump detects an alarm, the LED switches from green to red. This can mean one of the following:

- low supply voltage
- blocked rotor
- electrical error.

The alarms for blocked rotor and electrical error can be read via the PWM return signal, while all three alarms can be read via the LIN bus signal.

### 7.2 UPM3 HYBRID variants

UPM3 HYBRID variants can be controlled both externally and internally.

#### 7.2.1 Operating panel

The operating panel is designed with a single button, one red/green LED and four yellow LEDs.

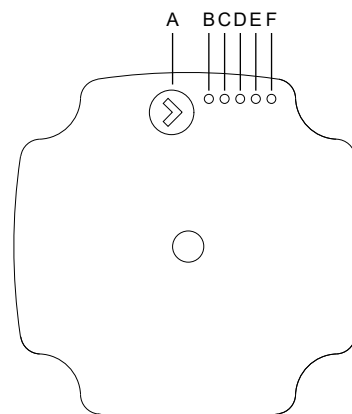

TM0605351

Operating panel with one button and five LEDs

Pos.	Description
A	Push button
B	LED 1
C	LED 2
D	LED 3
E	LED 4
F	LED 5

The operating panel shows:

- control mode
- alarm status.

#### 7.2.2 Alarm status

If the pump detects one or more alarms, LED 1 switches from green to red and one of the other LEDs lights yellow.

If multiple alarms are active at the same time, the LEDs only show the error of the highest priority. The priority is defined by the sequence of the table as shown in the fault finding information.

When there is no active alarm anymore, the operating panel switches back to operating mode.

#### Related information

[11.7 Fault indication on the operating panel](#)

### 7.3 Control modes

#### 7.3.1 Changing the control mode

To set the product, use the button on the operating panel. Every time you press the button, the pump setting is changed. The LEDs indicate the chosen control mode.

#### 7.4 Overview of operating panel control modes

All UPM3 HYBRID variants can be controlled with the button on the operating panel.

The LEDs on the operating panel shows the control mode.

#### Related information

[6.2 Starting up the product](#)

### 7.4.1 UPM3 HYBRID

This pump is either externally controlled with PWM signal with profile A or C or internally with three control modes with AUTOADAPT (AA).

Control mode	LED1 green	LED2 green	LED3 yellow	LED4 yellow	LED5 yellow
PP AA	•				
CP AA		•			
PP1	•		•		
PP2	•		•	•	
PP3	•		•	•	•
CP1		•	•		
CP2		•	•	•	
CP3		•	•	•	•
CC1			•		
CC2			•	•	
CC3			•	•	•
PWM C signal off		• <sup>3)</sup>	•	•	•
PWMC signal on		• <sup>4)</sup>	•	•	•
PWM A curve 1 signal off	• <sup>3)</sup>		•		
PWM A curve 1 signal on	• <sup>4)</sup>		•		
PWM A curve 2 signal off	• <sup>3)</sup>		•	•	
PWM A curve 2 signal on	• <sup>4)</sup>		•	•	
PWM A curve 3 signal off	• <sup>3)</sup>		•	•	•
PWM A curve 3 signal on	• <sup>4)</sup>		•	•	•

3) 1 flash per second.

4) 12 flashes per second.

### 7.4.2 UPM3 FLEX AS and UPM3 DHW

This pump is either externally controlled with a PWM A profile signal control or speed selection.

The maximum curve of the pump operating range can be defined.

- With PWM signal, the pump runs at the corresponding speed.
- Without PWM signal, the pump runs at maximum speed.

PWM A profile	LED1 green	LED2 green	LED3 yellow	LED4 yellow	LED5 yellow
PWM A curve 1 signal off	• <sup>5)</sup>		•		
PWM A curve 1 signal on	• <sup>6)</sup>		•		
PWM A curve 2 signal off	• <sup>5)</sup>		•	•	
PWM A curve 2 signal on	• <sup>6)</sup>		•	•	
PWM A curve 3 signal off	• <sup>5)</sup>		•	•	•
PWM A curve 3 signal on	• <sup>6)</sup>		•	•	•

5) 1 flash per second.

6) 12 flashes per second.

### 7.4.3 UPM3 SOLAR

This pump is either externally controlled with PWM signal control with profile C or internally on constant curve mode.

Control mode	LED1 green	LED2 green	LED3 yellow	LED4 yellow	LED5 yellow
CC1			•		
CC2			•	•	
CC3			•	•	•
PWM C signal off		• <sup>7)</sup>	•	•	•
PWM C signal on		• <sup>8)</sup>	•	•	•

7) 1 flash per second.

8) 12 flashes per second.

### 7.4.4 UPM3 AUTO

This pump is internally controlled with three control modes with AUTOADAPT (AA).

Control mode	LED1 green	LED2 green	LED3 yellow	LED4 yellow	LED5 yellow
PP AA	•				
CP AA		•			
PP1	•		•		
PP2	•		•	•	
PP3	•		•	•	•
CP1		•	•		
CP2		•	•	•	
CP3		•	•	•	•
CC1			•		
CC2			•	•	
CC3			•	•	•

### 7.4.5 UPMO

This pump is internally controlled with control mode CC or externally with PWM signal control with profile A.

The pump automatically enables the PWM input-signal control mode by SignalDetect when the signal cable is plugged in.

Control mode	LED1 green	LED2 green	LED3 yellow	LED4 yellow	LED5 yellow
CC1			•		
CC2			•	•	
CC3			•	•	•
PWM A	• <sup>9)</sup>		•	•	•

9) 12 flashes per second.

If the pump does not detect a PWM signal or if the signal equals 0, the pump returns to its previous control mode.

## 7.5 Control mode explanation

### 7.5.1 Proportional pressure

The head (pressure) is reduced at falling heat demand and increased at rising heat demand.

The duty point of the pump moves up or down on the selected proportional-pressure curve depending on the heat demand in the system.



- PP1: lowest proportional-pressure curve
- PP2: intermediate proportional-pressure curve
- PP3: highest proportional-pressure curve
- AUTOADAPT: highest to lowest proportional pressure curve.

The AUTOADAPT function enables the pump to control the pump performance automatically within a defined performance range:

- adjusting the pump performance to the size of the system
- adjusting the pump performance to the variations in load over time.

In proportional pressure AUTOADAPT, the pump is set to proportional-pressure control.

### 7.5.2 Constant pressure

The head (pressure) is kept constant, irrespective of the heat demand.

The duty point of the pump moves out or in on the selected constant-pressure curve depending on the heat demand in the system.



TM060705

- CP1: lowest constant-pressure curve
- CP2: intermediate constant-pressure curve
- CP3: highest constant-pressure curve
- AUTOADAPT: highest to lowest constant-pressure curve.

The AUTOADAPT function enables the pump to control the pump performance automatically within a defined performance range:

- adjusting the pump performance to the size of the system.
- adjusting the pump performance to the variations in load over time.

In constant pressure AUTOADAPT, the pump is set to constant-pressure control.

### 7.5.3 Constant curve

The pump runs on a constant curve, which means that it runs at a constant speed or power.

The duty point of the pump moves up or down on the selected constant curve, depending on the heat demand in the system.



TM060805

	Head [m]					
	UPM3 XX-20	UPM3 XX-50	UPM3 XX-70	UPM3 XX-75	UPM3 XX-105	UPM3 XX-145
CC1	1.0	3	5	5	6.5	8.5
CC2	1.5	4	6	6	8.5	10.5
CC3 (max.)	2	5	7	7.5	10.5	14.5

### 7.5.4 PWM A profile (heating)

The pump runs on constant speed curves depending on the current PWM value.

The speed decreases when the PWM value increases. If PWM equals 0, the pump runs at maximum speed.



TM060706

PWM profile	Head[m]			
	UPM3 XX-20	UPM3 XX-50	UPM3 XX-70	UPM3 XX-75
A1	1.0	3	5	5
A2	1.5	4	6	6
A3 (max.)	2.0	5	7	7.5
MAX	UPM3 XX-20	UPM3 XX-50	UPM3 XX-70	UPM3 XX-75

PWM profile	Head[m]			
	UPM3 XX-20	UPM3 XX-50	UPM3 XX-70	UPM3 XX-75
A1	1.0	3	5	5
A2	1.5	4	6	6
A3	2.0	5	7	7.5

### 7.5.5 PWM C profile (solar)

The pump runs on constant speed curves depending on the current PWM value.

Speed increases when the PWM value increases. If PWM equals 0, the pump stops.







TM060707

PWM profile	Head[m]				
	UPM3 XX-50	UPM3 XX-70	UPM3 XX-75	UPM3 XX-105	UPM3 XX-145
C1	3	5	5	6.5	8.5
C2	4	6	6	8.5	10.5
C3 (max.)	5	7	7.5	10.5	14.5

### 7.6 Selection of control mode

The selection of the control mode depends on the system type and the allocation of pressure losses defined by the valve or consumer authority.

System type		Recommended control mode
Heating system with PWM control of the pump		PWM A profile 
Solar system with PWM control of the pump		PWM C profile 
System without PWM control of the pump (stand-alone)		Internally controlled
Variable-flow system with relatively high pressure losses inside heating appliance and pipes (> 50 % of pump head)	Two-pipe systems with thermostatic radiator valve with low valve authority	$H_N > 2$ m for noise reduction Long distribution pipes High pressure losses in system parts with total flow Heat consumers with low pressure losses Proportional pressure / AUTOADAPT proportional pressure 
	Primary pump	Primary circuit with high pressure losses
Variable-flow system with relatively low pressure losses inside heating appliance and pipes (< 50 % of pump head)	Two-pipe systems with thermostatic radiator valve with high valve authority	$H_N \leq 2$ m for noise reduction Former gravity systems Low pressure losses in system parts with total flow Heat consumers with high pressure losses Constant pressure / AUTOADAPT constant pressure 
	Floor heating system with variable flow	System with thermostatic zone valves
	One-pipe system with variable flow	System with thermostatic radiator valves
	Primary pump	Primary circuit with low pressure losses
	Systems with low flow variation	Systems with minimum flow ensured by an automatic bypass valve
Constant flow systems		Constant curve 

## 8. External control mode and signals

### 8.1 Control principles

The UPM3 and UPM3 FLEX pumps are controlled via a digital low-voltage pulse-width modulation (PWM) signal, which means that the speed of rotation depends on the input signal.

UPM3 HYBRID pumps can be set to be controlled either internally or externally. The speed changes as a function of the input profile. These communication signals are standardised in the VDMA Einheitsblatt 24244 "Wet runner circulating pumps - Specification of PWM control signals".

### 8.2 Control signals

#### 8.2.1 Digital low-voltage PWM signal



**WARNING**  
**Explosive environment**

Death or serious personal injury

- Do not exceed the specified maximum voltage on the PWM output or the output circuit may overheat.

The square-wave PWM signal is designed for a 100 to 1500 Hz frequency range. The PWM signal is used to select the speed (speed command) and as feedback signal. The PWM frequency on the feedback signal is fixed at 75 Hz in the pump.

**Duty cycle**

$$d \% = 100 \times t/T$$

Example	Rating
T = 2 ms (500 Hz)	$U_{IH} = 4-24\text{ V}$
t = 0.6 ms	$U_{IL} \leq 1\text{ V}$
d % = $100 \times 0.6 / 2 = 30\%$	$4.5\text{ mA} \leq I_h \leq 10\text{ mA}$ (depending on $U_{IH}$ )

Example

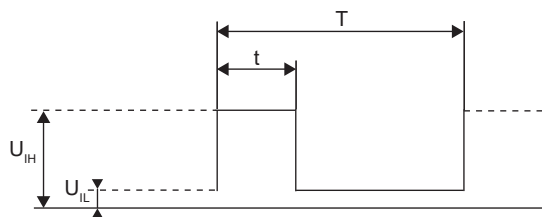

TM049911

PWM signal

Abbreviation	Description
T	Period of time [sec.]
d	Duty cycle [t/T]
$U_{IH}$	High-level input voltage
$U_{IL}$	Low-level input voltage
$I_{IH}$	High-level input current

### 8.2.2 PWM input signal profile A (heating)

At high PWM signal percentages (duty cycles), a hysteresis prevents the pump from starting and stopping if the input signal fluctuates around the shifting point. At low PWM signal percentages, the pump speed is high for safety reasons. In case a cable breaks when mounted in a system, the pump starts to run at maximum speed. This is suitable for both boilers and heat pumps to ensure that the pump transfers heat even if a cable breaks.

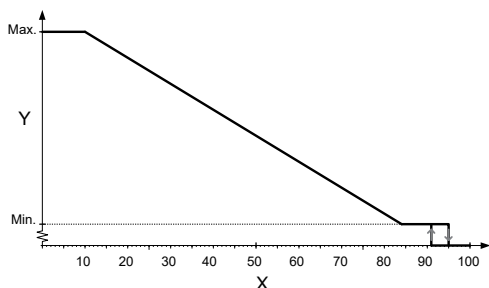

TM049985

PWM input profile A (heating)

Axis	Value
X	PWM input signal [%]
Y	Speed

PWM input signal [%]	Pump status
$\leq 10$	Maximum speed
$> 10 / \leq 84$	Variable speed from minimum to maximum speed
$> 84 / \leq 91$	Minimum speed
$> 91/95$	Hysteresis area: on/off
$> 95 / \leq 100$	Standby mode: off

### 8.2.3 PWM input signal profile C (solar)

At low PWM signal percentages (duty cycles), a hysteresis prevents the pump from starting and stopping if the input signal fluctuates around the shifting point. Without PWM signal percentages, the

pump stops for safety reasons. If a signal is missing, for example if a cable breaks, the pump stops to avoid overheating of the solar thermal system.

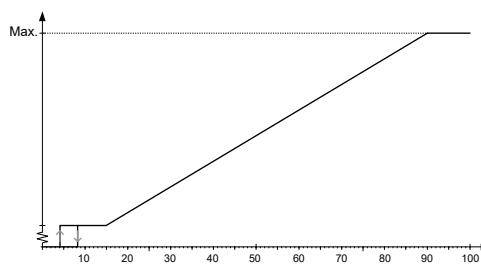

TM051575

PWM input profile C (solar)

Axis	Value
X	PWM input signal [%]
Y	Speed

PWM input signal [%]	Pump status
$\leq 5$	Standby mode: off
$> 5 / \leq 8$	Hysteresis area: on/off
$> 8 / \leq 15$	Minimum speed
$> 15 / \leq 90$	Variable speed from minimum to maximum speed
$> 90 / \leq 100$	Maximum speed

### 8.2.4 PWM feedback signal (standard)

The PWM feedback signal offers the same pump information as in bus systems:

- current power consumption (accuracy  $\pm 2\%$  of PWM signal)
- warning
- alarm
- operating status.

### Alarms

Alarm output signals are available because some PWM output signals are dedicated to alarm information. If a supply voltage is measured below the specified supply voltage range, the output signal is set to 75 %. If the rotor is locked due to deposits in the hydraulics, the output signal is set to 90 % as this alarm has a higher priority.

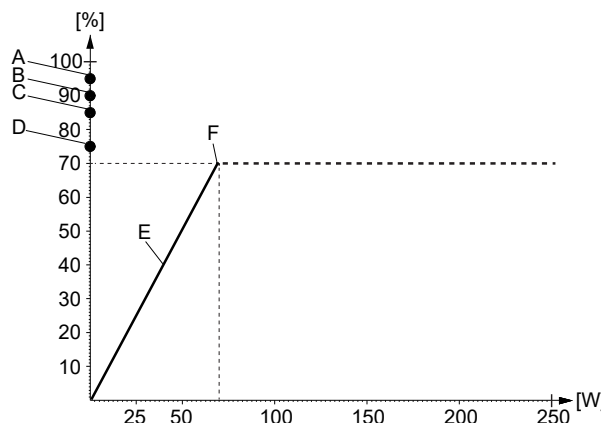

TM050006

PWM feedback signal, UPM3 power consumption

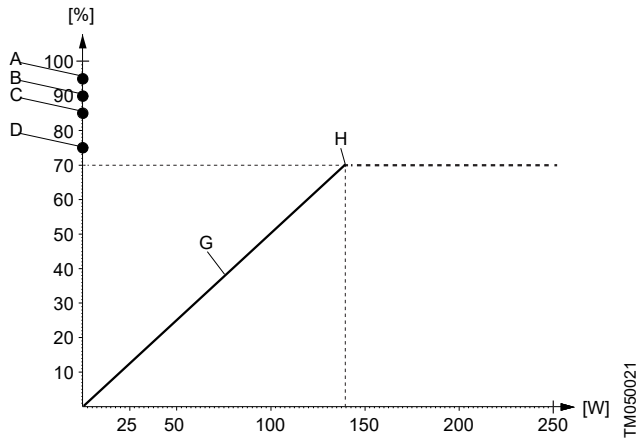

PWM feedback signal, UPM3L power consumption

Maximum rating	Symbol	Value
Maximum power dissipation on output resistor	$P_R$	125 mW
Zener diode working voltage	$U_Z$	36 V
Maximum power dissipation in Zener diode	$P_Z$	300 mW

<sup>10)</sup> Only for standard profiles.

Pos.	Description
X-axis	Output power consumption [W]
Y-axis	PWM output signal in percentage [%]
A	Standby (stop)
B	Alarm stop: fault, blocked pump
C	Alarm stop: electrical fault
D	Warning
E	Slope: 1 % / watt PWM signal
F	Saturation at 70 W
G	Slope: 2 % / watt PWM signal
H	Saturation at 140 W

PWM output signal [%]	QT [s]	Pump info	DT [s]	Priority
95	0	Standby (stop) by PWM signal	0	1
90	30	Alarm, stop, blocked error	12	2
85	0-30	Alarm, stop, electrical error	1-12	3
75	0	Warning	0	5
0-70		0-70 W (slope 1 W/% PWM)		6

Output frequency: 75 Hz  $\pm$  5 %

QT = qualification time, DT = disqualification time

**8.2.5 Control signal data levels**

Maximum rating	Symbol	Value
PWM frequency input with high-speed optocoupler	$f$	100-4000 Hz <sup>10)</sup>
Rated input voltage - high level	$U_{iH}$	4-24 V
Rated input voltage - low level	$U_{iL}$	< 1 V
High-level input current	$I_{iH}$	< 10 mA
Input duty cycle	PWM	0-100 %
PWM frequency output, open collector	$f$	75 Hz $\pm$ 5 %
Accuracy of output signal regarding power consumption	-	$\pm$ 2 % (of PWM signal)
Output duty cycle	PWM	0-100 %
Collector emitter breakdown voltage on output transistor	$U_c$	< 70 V
Collector current on output transistor	$I_c$	< 50 mA

## 9. Service

### **DANGER** Electric shock

Death or serious personal injury



- Before dismantling the complete pump installation, switch off the power supply at least 5 minutes before beginning work.
- Make sure that the power supply cannot be switched on accidentally.

### **DANGER** Electric shock

Death or serious personal injury



- The pump is running in turbine mode and acts as a generator. It creates hazardous induction voltage at the motor terminals.
- Prevent the fluid from flowing through the pump by closing the shut-off valves.

### **WARNING** Pressurised system

Death or serious personal injury



- Before dismantling the pump, drain the system or close the isolating valve on either side of the pump. The pumped liquid may be scalding hot and under high pressure.

### **WARNING** Biological hazard

Death or serious personal injury



- Always use original spare parts.

### **WARNING** Electric shock

Death or serious personal injury



- Connect the product to protective earth and provide protection against indirect contact in accordance with local regulations.

### **WARNING** Hot surface

Death or serious personal injury



- The pump housing may be hot due to the pumped liquid being scalding hot.
- Close the isolating valves on both sides of the pump and wait for the pump housing to cool down.

### **WARNING** Electric shock

Death or serious personal injury



- In case of an insulation fault, the fault current may be a pulsating DC. Observe national legislation about requirements for and selection of Residual Current Device (RCD) when installing the product.

### **WARNING** Magnetic field

Death or serious personal injury



- If you have a pacemaker, keep a safety distance of at least 0.3 m when dismantling the pump.

### **WARNING** Toxic material

Death or serious personal injury



- Decontaminate pumps that handle fluids pose a health hazard.

### **WARNING** General hazard

Death or serious personal injury



- All service work must be carried out by an instructed service technician.



### **CAUTION** Crushing of feet

Minor or moderate personal injury

- Wear personal protective equipment.

## 9.1 Maintaining the product

The pumps are maintenance-free. However, it might be necessary to deblock or to open the pump, for example, if it is blocked by impurities.

Deblocking is possible by opening the deblocking screw at the front.

1. Unscrew the deblocking screw at the front of the pump head.



### **CAUTION** Pressurised system

Minor or moderate personal injury

- Be aware of splashing hot water.

2. Deblock the pump with a screwdriver.

## 9.2 Cleaning the product

If the impeller or pump housing has to be cleaned from impurities, proceed as follows:

1. Drain the system or close the isolating valves.



### **CAUTION** Pressurised system

Minor or moderate personal injury

- Be aware of splashing hot water.

2. Remove the screws that hold the pump head.
3. Check the impeller and pump housing and remove the impurities.
4. Place the pump head in the desired position, fit the screws and tighten them securely.

## 10. Storing the product

- Observe the permissible ambient conditions.
- Observe the permissible storage temperature: -40 to +75 °C.
- Protect the storage location from rain, humidity, condensation, direct sunlight and dust.
- Maximum storage time (without power supply): 2 years from delivery.

### Related information

[12.1.1 Ambient and liquid temperature](#)

## 11. Fault finding

### 11.1 Noise in the pump

Cause	Remedy
There is air in the pump.	<ul style="list-style-type: none"> <li>Let the pump run. The pump vents itself over time.</li> </ul>
The inlet pressure is too low.	<ul style="list-style-type: none"> <li>Increase the system pressure or check the air volume in the expansion tank, if installed.</li> </ul>

### 11.2 Noise in the system

Cause	Remedy
There is air in the system.	<ul style="list-style-type: none"> <li>Vent the system.</li> </ul>
The differential pressure is too high.	<ul style="list-style-type: none"> <li>Reduce the pump performance at the pump or the external controller.</li> </ul>

### 11.3 Pump is not running, no power supply

Cause	Remedy
The system is switched off.	<ul style="list-style-type: none"> <li>Check the system controller.</li> </ul>
A fuse in the installation is blown.	<ul style="list-style-type: none"> <li>Replace the fuse.</li> </ul>
There is a power supply failure.	<ul style="list-style-type: none"> <li>Check the power supply.</li> </ul>

### 11.4 Pump is not running, normal power supply

Cause	Remedy
The controller is switched off.	<ul style="list-style-type: none"> <li>Check the controller and its settings.</li> </ul>

### 11.7 Fault indication on the operating panel

When an alarm is active, the LEDs indicate the alarm type as defined in the table below.

If multiple alarms are active at the same time, the LEDs only show the error with the highest priority. The priority is defined by the sequence of the table.

Operating panel					Indication	Pump operation	Counter action
LED1 red	LED2 green	LED3 yellow	LED4 yellow	LED5 yellow			
•				•	Rotor is blocked.	Trying to start again every 1.33 seconds.	Wait or deblock the shaft.
•			•		Supply voltage too low.	Only warning, pump runs.	Control the supply voltage.
•		•			Electrical error.	Pump is stopped because of low supply voltage or serious failure.	Control the supply voltage. Replace the pump.

#### Related information

[5.2.1 Reduced supply voltage](#)

[7.2.2 Alarm status](#)

Cause	Remedy
The pump is blocked by impurities.	<ul style="list-style-type: none"> <li>Remove impurities. Deblock the pump from the front of the control box with a screwdriver.</li> </ul>
The pump is defective.	<ul style="list-style-type: none"> <li>Replace the pump.</li> </ul>

### 11.5 Insufficient flow

Cause	Remedy
The pump performance is too low.	<ul style="list-style-type: none"> <li>Check the external controller and the pump settings.</li> </ul>
The hydraulic system is closed or the system pressure is insufficient.	<ul style="list-style-type: none"> <li>Check the non-return valve and the filter.</li> <li>Increase the system pressure.</li> </ul>

### 11.6 Pump runs at maximum speed and cannot be controlled

Cause	Remedy
There is no signal from the signal cable.	<ul style="list-style-type: none"> <li>Check if the cable is connected to the controller. If it is connected, replace the cable.</li> </ul>

## 12. Technical data

### 12.1 Operating conditions

#### 12.1.1 Ambient and liquid temperature

The ambient and liquid temperature of the specific pump is indicated in the table below. The ambient temperature is measured in a distance of not more than 5 cm in front of the front foil at its lower edge.

		55 °C ambient at 95 °C liquid temperature	70 °C ambient at 65 °C liquid temperature	70 °C ambient at 110 °C liquid temperature	60 °C ambient at 130 °C liquid temperature	95 °C ambient temperature
<b>Standard variants</b>						
GFNHB	UPM3S			•	•	•
GFNKB	UPM3			•	•	•
GFNKC	UPM3L	•		•	•	
GFNFB	UPM3			•	•	•

The above-mentioned temperature ranges do not take temperature limitations of the drinking water approvals into account.

- UPM3, IP44 above dew point of ambient air: min. 2 °C
- UPM3, IP4XD as K version with drain hole: min. -10 °C.

#### Related information

##### 10. Storing the product

#### 12.1.2 Relative humidity

IP44: The relative humidity must not exceed 95 % in a non-condensing environment.



The dew point of the air at ambient temperature must always be lower than the liquid temperature, otherwise condensation may form in the stator housing.

K-Version/IPX4D: Condensation is acceptable.

#### 12.1.3 Minimum inlet pressure

To avoid cavitation and damage to the pump bearings, the following minimum pressures are required at the pump inlet port.

Liquid temperature	75 °C	95 °C	110 °C
Pressure	0.005 MPa 0.05 bar	0.05 MPa 0.5 bar	0.108 MPa 1.08 bar

## 13. Disposing of the product

This product or parts of it must be disposed of in an environmentally sound way.

1. Use the public or private waste collection service.
2. If this is not possible, contact the nearest Grundfos company or service workshop.



The crossed-out wheellie bin symbol on a product means that it must be disposed of separately from household waste. When a product marked with this symbol reaches its end of life, take it to a collection point designated by the local waste disposal authorities. The separate collection and recycling of such products will help protect the environment and human health.

See also end-of-life information at [www.grundfos.com/product-recycling](http://www.grundfos.com/product-recycling).

## Declaration of conformity

---

### GB: EU declaration of conformity

We, Grundfos, declare under our sole responsibility that the products GFNFB, GFNHB, GFNKB and GFNKC, to which the declaration below relates, are in conformity with the Council Directives listed below on the approximation of the laws of the EU member states.

---

- Low Voltage Directive (2014/35/EU).  
Standard used:  
EN 60335-1:2012 + AC:2014 + A11:2014 + A13:2017 + A1:2019 + A14:2019 + A2:2019 + A15:2021  
EN 60335-2-51:2003+A1:2008+A2:2012
- EMC Directive (2014/30/EU)  
Standards used:  
EN 55014-1:2017  
EN 55014-2:2015  
EN 61000-3-2:2014  
EN 61000-3-3:2013
- RoHS Directive 2011/65/EU and 2015/863//EU  
Standard used:  
EN IEC 63000:2018
- Ecodesign Directive (2009/125/EC)  
Commission Regulation (EC) No 641/2009  
Commission Regulation (EC) No 622/2012  
Standard used:  
EN 16297-1:2012  
EN 16297-2:2012  
EN16297-3:2012

$EEL \leq 0.23$  (see individual data sheet or name plate).

The benchmark for the most efficient circulators is  $EEL \leq 0.20$ .

Bjerringbro, 15 February 2023



Jannek Uldal-Christesen  
Senior Director  
Grundfos Holding A/S  
Poul Due Jensens Vej 7  
8850 Bjerringbro, Denmark

Person authorised to compile technical file and empowered to sign the EU declaration of conformity.

## Declaration of conformity

---

### UK declaration of conformity

We, Grundfos, declare under our sole responsibility that the products to which the declaration below relates, are in conformity with UK regulations, standards and specifications to which conformity is declared, as listed below:

Valid for products:

GFNFB, GFNHB,GFNKB and GFNKC.

---

- Electrical Equipment (Safety) Regulations 2016  
Standards used: EN 60335-1:2012 + AC:2014 + A11:2014 + A13:2017 + A1:2019 + A14:2019 + A2:2019 + A15:2021.
- Electromagnetic Compatibility Regulations 2016  
Standards used: BS EN 55014-1: 2017,BS EN 55014-2: 2015,BS EN 61000-3-2: 2014,BS EN 61000-3-3:2013
- The Restriction of the Use of Certain Hazardous Substances in Electrical and Electronic Equipment Regulations 2012  
Standards used: BS EN IEC 63000: 2018
- The Ecodesign for Energy-Related Products and Energy Information (Amendment) (EU Exit) Regulations 2019 using Regulation (EC) No 641/2009 and Regulation (EU) No 622/2012.  
Standards used:  
BS EN 16297-1: 2012, BS EN 16297-2: 2012, BS EN 16297-3: 2012  
EEI ≤ 0.23 (see individual data sheet or name plate).  
The benchmark for the most efficient circulators is EEI ≤ 0.20.

Bjerringbro, February 15th 2023



Jannek Uldal-Christesen  
Senior Director  
Grundfos Holding A/S  
Poul Due Jensens Vej 7  
8850 Bjerringbro, Denmark

Manufacturer and person empowered to sign the UK declaration of conformity.

**Argentina**

Bombas GRUNDFOS de Argentina S.A.  
Ruta Panamericana km. 37.500 Indust  
1619 - Garin Pcia. de B.A.  
Tel.: +54-3327 414 444  
Fax: +54-3327 45 3190

**Australia**

GRUNDFOS Pumps Pty. Ltd.  
P.O. Box 2040  
Regency Park  
South Australia 5942  
Tel.: +61-8-8461-4611  
Fax: +61-8-8340-0155

**Austria**

GRUNDFOS Pumpen Vertrieb Ges.m.b.H.  
Grundfosstraße 2  
A-5082 Grödig/Salzburg  
Tel.: +43-6246-883-0  
Fax: +43-6246-883-30

**Belgium**

N.V. GRUNDFOS Bellux S.A.  
Boomsesteenweg 81-83  
B-2630 Aartselaar  
Tel.: +32-3-870 7300  
Fax: +32-3-870 7301

**Bosnia and Herzegovina**

GRUNDFOS Sarajevo  
Zmaj od Bosne 7-7A  
BiH-71000 Sarajevo  
Tel.: +387 33 592 480  
Fax: +387 33 590 465  
www.ba.grundfos.com  
E-mail: grundfos@bih.net.ba

**Brazil**

BOMBAS GRUNDFOS DO BRASIL  
Av. Humberto de Alencar Castelo Branco,  
630  
CEP 09850 - 300  
São Bernardo do Campo - SP  
Tel.: +55-11 4393 5533  
Fax: +55-11 4343 5015

**Bulgaria**

Grundfos Bulgaria EOOD  
Slatina District  
Iztochna Tangenta street no. 100  
BG - 1592 Sofia  
Tel.: +359 2 49 22 200  
Fax: +359 2 49 22 201  
E-mail: bulgaria@grundfos.bg

**Canada**

GRUNDFOS Canada inc.  
2941 Brighton Road  
Oakville, Ontario  
L6H 6C9  
Tel.: +1-905 829 9533  
Fax: +1-905 829 9512

**China**

GRUNDFOS Pumps (Shanghai) Co. Ltd.  
10F The Hub, No. 33 Suhong Road  
Minhang District  
Shanghai 201106 PRC  
Tel.: +86 21 612 252 22  
Fax: +86 21 612 253 33

**Columbia**

GRUNDFOS Colombia S.A.S.  
Km 1.5 vía Siberia-Cota Conj. Potrero  
Chico,  
Parque Empresarial Arcos de Cota Bod. 1A.  
Cota, Cundinamarca  
Tel.: +57(1)-2913444  
Fax: +57(1)-8764586

**Croatia**

GRUNDFOS CROATIA d.o.o.  
Buzinski prilaz 38, Buzin  
HR-10010 Zagreb  
Tel.: +385 1 6595 400  
Fax: +385 1 6595 499  
www.hr.grundfos.com

**Czech Republic**

GRUNDFOS Sales Czechia and Slovakia  
s.r.o.  
Čajkovského 21  
779 00 Olomouc  
Tel.: +420-585-716 111

**Denmark**

GRUNDFOS DK A/S  
Martin Bachs Vej 3  
DK-8850 Bjerringbro  
Tel.: +45-87 50 50 50  
Fax: +45-87 50 51 51  
E-mail: info\_GDK@grundfos.com  
www.grundfos.com/DK

**Estonia**

GRUNDFOS Pumps Eesti OÜ  
Peterburi tee 92G  
11415 Tallinn  
Tel.: + 372 606 1690  
Fax: + 372 606 1691

**Finland**

OY GRUNDFOS Pumput AB  
Trukkikuja 1  
FI-01360 Vantaa  
Tel.: +358-(0) 207 889 500

**France**

Pompes GRUNDFOS Distribution S.A.  
Parc d'Activités de Chesnes  
57, rue de Malacombe  
F-38290 St. Quentin Fallavier (Lyon)  
Tel.: +33-4 74 82 15 15  
Fax: +33-4 74 94 10 51

**Germany**

GRUNDFOS GMBH  
Schlüterstr. 33  
40699 Erkrath  
Tel.: +49-(0) 211 929 69-0  
Fax: +49-(0) 211 929 69-3799  
E-mail: infoservice@grundfos.de  
Service in Deutschland:  
kundendienst@grundfos.de

**Greece**

GRUNDFOS Hellas A.E.B.E.  
20th km. Athinon-Markopoulou Av.  
P.O. Box 71  
GR-19002 Peania  
Tel.: +0030-210-66 83 400  
Fax: +0030-210-66 46 273

**Hong Kong**

GRUNDFOS Pumps (Hong Kong) Ltd.  
Unit 1, Ground floor, Siu Wai industrial  
Centre  
29-33 Wing Hong Street & 68 King Lam  
Street, Cheung Sha Wan  
Kowloon  
Tel.: +852-27861706 / 27861741  
Fax: +852-27858664

**Hungary**

GRUNDFOS Hungária Kft.  
Tópark u. 8  
H-2045 Törökbálint  
Tel.: +36-23 511 110  
Fax: +36-23 511 111

**India**

GRUNDFOS Pumps india Private Limited  
118 Old Mahabalipuram Road  
Thoraiakkam  
Chennai 600 097  
Tel.: +91-44 2496 6800

**Indonesia**

PT GRUNDFOS Pompa  
Graha intrub Lt. 2 & 3  
Jln. Cililitan Besar No.454. Makasar,  
Jakarta Timur  
ID-Jakarta 13650  
Tel.: +62 21-469-51900  
Fax: +62 21-460 6910 / 460 6901

**Ireland**

GRUNDFOS (Ireland) Ltd.  
Unit A, Merrywell Business Park  
Ballymount Road Lower  
Dublin 12  
Tel.: +353-1-4089 800  
Fax: +353-1-4089 830

**Italy**

GRUNDFOS Pompe Italia S.r.l.  
Via Gran Sasso 4  
I-20060 Truccazzano (Milano)  
Tel.: +39-02-95838112  
Fax: +39-02-95309290 / 95838461

**Japan**

GRUNDFOS Pumps K.K.  
1-2-3, Shin-Miyakoda, Kita-ku  
Hamamatsu  
431-2103 Japan  
Tel.: +81 53 428 4760  
Fax: +81 53 428 5005

**Kazakhstan**

Grundfos Kazakhstan LLP  
7' Kyz-Zhibek Str., Kok-Tobe micr.  
KZ-050020 Almaty Kazakhstan  
Tel.: +7 (727) 227-98-55/56

**Korea**

GRUNDFOS Pumps Korea Ltd.  
6th Floor, Aju Building 679-5  
Yeoksam-dong, Kangnam-ku, 135-916  
Seoul, Korea  
Tel.: +82-2-5317 600  
Fax: +82-2-5633 725

**Latvia**

SIA GRUNDFOS Pumps Latvia  
Deglava biznesa centrs  
Augusta Deglava ielā 60  
LV-1035, Rīga,  
Tel.: + 371 714 9640, 7 149 641  
Fax: + 371 914 9646

**Lithuania**

GRUNDFOS Pumps UAB  
Smolensko g. 6  
LT-03201 Vilnius  
Tel.: +370 52 395 430  
Fax: +370 52 395 431

**Malaysia**

GRUNDFOS Pumps Sdn. Bhd.  
7 Jalan Peguam U1/25  
Glenmarie industrial Park  
40150 Shah Alam, Selangor  
Tel.: +60-3-5569 2922  
Fax: +60-3-5569 2866

**Mexico**

Bombas GRUNDFOS de México  
S.A. de C.V.  
Boulevard TLC No. 15  
Parque industrial Stiva Aeropuerto  
Apodaca, N.L. 66600  
Tel.: +52-81-8144 4000  
Fax: +52-81-8144 4010

**Netherlands**

GRUNDFOS Netherlands  
Veluwezoom 35  
1326 AE Almere  
Postbus 22015  
1302 CA ALMERE  
Tel.: +31-88-478 6336  
Fax: +31-88-478 6332  
E-mail: info\_gnl@grundfos.com

**New Zealand**

GRUNDFOS Pumps NZ Ltd.  
17 Beatrice Tinsley Crescent  
North Harbour Industrial Estate  
Albany, Auckland  
Tel.: +64-9-415 3240  
Fax: +64-9-415 3250

**Norway**

GRUNDFOS Pomper A/S  
Stramsveien 344  
Postboks 235, Leirdal  
N-1011 Oslo  
Tel.: +47-22 90 47 00  
Fax: +47-22 32 21 50

**Poland**

GRUNDFOS Pompy Sp. z o.o.  
ul. Klonowa 23  
Baranowo k. Poznania  
PL-62-081 Przeźmierowo  
Tel.: (+48-61) 650 13 00  
Fax: (+48-61) 650 13 50

**Portugal**

Bombas GRUNDFOS Portugal, S.A.  
Rua Calvet de Magalhães, 241  
Apartado 1079  
P-2770-153 Paço de Arcos  
Tel.: +351-21-440 76 00  
Fax: +351-21-440 76 90

**Romania**

GRUNDFOS Pompe România SRL  
S-PARK BUSINESS CENTER, Clădirea  
A2, etaj 2  
Str. Tipografilor, Nr. 11-15, Sector 1, Cod  
013714  
Bucuresti, Romania  
Tel.: 004 021 2004 100  
E-mail: romania@grundfos.ro

**Serbia**

Grundfos Srbija d.o.o.  
Omladinskih brigada 90b  
11070 Novi Beograd  
Tel.: +381 11 2258 740  
Fax: +381 11 2281 769  
www.rs.grundfos.com

**Singapore**

GRUNDFOS (Singapore) Pte. Ltd.  
25 Jalan Tukang  
Singapore 619264  
Tel.: +65-6681 9688  
Fax: +65-6681 9689

**Slovakia**

GRUNDFOS s.r.o.  
Prievozská 4D 821 09 BRATISLAVA  
Tel.: +421 2 5020 1426  
sk.grundfos.com

**Slovenia**

GRUNDFOS LJUBLJANA, d.o.o.  
Leskoškova 9e, 1122 Ljubljana  
Tel.: +386 (0) 1 568 06 10  
Fax: +386 (0) 1 568 06 19  
E-mail: tehnika-si@grundfos.com

**South Africa**

GRUNDFOS (PTY) LTD  
16 Lascelles Drive, Meadowbrook Estate  
1609 Germiston, Johannesburg  
Tel.: (+27) 10 248 6000  
Fax: (+27) 10 248 6002  
E-mail: Igradidge@grundfos.com

**Spain**

Bombas GRUNDFOS España S.A.  
Camino de la Fuenteçilla, s/n  
E-28110 Algete (Madrid)  
Tel.: +34-91-848 8800  
Fax: +34-91-628 0465

**Sweden**

GRUNDFOS AB  
Box 333 (Lunnagårdsgatan 6)  
431 24 Mölndal  
Tel.: +46 31 332 23 000  
Fax: +46 31 331 94 60

**Switzerland**

GRUNDFOS Pumpen AG  
Bruggacherstrasse 10  
CH-8117 Fällanden/ZH  
Tel.: +41-44-806 8111  
Fax: +41-44-806 8115

**Taiwan**

GRUNDFOS Pumps (Taiwan) Ltd.  
7 Floor, 219 Min-Chuan Road  
Taichung, Taiwan, R.O.C.  
Tel.: +886-4-2305 0868  
Fax: +886-4-2305 0878

**Thailand**

GRUNDFOS (Thailand) Ltd.  
92 Chaloein Phrakiat Rama 9 Road  
Dokmai, Pravej, Bangkok 10250  
Tel.: +66-2-725 8999  
Fax: +66-2-725 8998

**Turkey**

GRUNDFOS POMPA San. ve Tic. Ltd. Sti.  
Gebze Organize Sanayi Bölgesi  
İhsan dede Caddesi  
2. yol 200. Sokak No. 204  
41490 Gebze/ Kocaeli  
Tel.: +90 - 262-679 7979  
Fax: +90 - 262-679 7905  
E-mail: satis@grundfos.com

**Ukraine**

ТОВ "ГРУНДФОС УКРАЇНА"  
Бізнес Центр Європа  
Столичне шосе, 103  
м. Київ, 03131, Україна  
Tel.: (+38 044) 237 04 00  
Fax: (+38 044) 237 04 01  
E-mail: ukraine@grundfos.com

**United Arab Emirates**

GRUNDFOS Gulf Distribution  
P.O. Box 16768  
Jebel Ali Free Zone, Dubai  
Tel.: +971 4 8815 166  
Fax: +971 4 8815 136

**United Kingdom**

GRUNDFOS Pumps Ltd.  
Grovebury Road  
Leighton Buzzard/Beds. LU7 4TL  
Tel.: +44-1525-850000  
Fax: +44-1525-850011

**U.S.A.**

Global Headquarters for WU  
856 Koomey Road  
Brookshire, Texas 77423 USA  
Phone: +1-630-236-5500

**Uzbekistan**

Grundfos Tashkent, Uzbekistan  
The Representative Office of Grundfos  
Kazakhstan in Uzbekistan  
38a, Oybek street, Tashkent  
Tel.: (+998) 71 150 3290 / 71 150 3291  
Fax: (+998) 71 150 3292

<b>92626940</b> 08.2023
ECM: 1374997